

# ARCHAEO - ASTRONOMICAL PROSPECTING AT THE MOOSE HILL STONE CHAMBERS

Frederick W. Martin, Elizabeth F. Martin, Polly Midgley, and Walter Wheeler<sup>A</sup>

*The landscape surrounding the Kings Chamber, one of many corbelled dry-stone chambers sited along the river headwater streams of Putnam County in New York, has been paced on foot, measured by two-meter GPS, and surveyed to two-foot accuracy by solar-oriented transit. The skyline of the hill opposite this chamber contains large, well-separated stones. An hypothesis of human construction is offered, because 3 stones correlate well with a four-part solar year. If trees were absent, the sunset shadows made by these stones on the winter solstice, summer solstice and equinoxes would cross at a point inside an arc of large stones in front of the chamber. The chamber axis at azimuth 213 faces toward the most southerly possible moonset on the opposing horizon. The rising of this same moon can be viewed from the nearby smaller chamber, and some speculation is offered on lunar timing of burial ceremonies in Woodland times. Other stones on the horizon may correlate with the major lunar standstills, and with stellar directions nearer to the meridian, but do not suggest use of an 8-part year with solar cross-quarter days. Archaeological investigation with radiocarbon dating inside the chambers and around the stones is urged in order to help prove or disprove the hypothesis of human construction and date the chamber construction.*

## INTRODUCTION

Many stone remains outside of New England have been found to address the night sky. Astronomical sightlines have been identified at sites belonging to the Hopewell and Adena cultures of the Midwest (Romain 2004, 2000) and the later Mississippian of the South (Fowler and Krupp 1996). Stone remains have been found in the American Southwest (Malville 2008) and especially in Britain (Burl 2000). The field of archaeo-astronomy was enormously advanced by the work of Alexander Thom, a professor of civil engineering at Cambridge in the UK, who spent his summer vacations surveying stone circles (Thom 1967, 1971; Thom and Thom 1978).

In New England, the remains at Mystery Hill in Salem, New Hampshire, have been a continuing source of controversy, in which all sides agree that the central astronomical viewing point no longer exists (Feldman 1977, Lambert 1996). Following Thom's example Byron Dix set out to "visit all the NEARA sites in the state [of Vermont], searching for a place that would show that Thom's discoveries in Europe might have their parallel in the New World" (Hitching 1978:131). He soon found the Calendar I site, a mountain valley where the rising and setting sun at both solstices is marked by hilltop stones (Dix 1975; Dix and Mavor 1981). Excavation showed that the stones were set in two feet of accumulated earth, and chocked on bedrock in a bottom layer of type laid down soon after the departure of the glaciers (Mavor 1989:16). Recently a sunrise oriented calendar complex in southeastern Massachusetts has been carefully documented (Leonard 2010). Our systematic search in Massachusetts identified the astronomical nature of King Philip's Rocks (Ballard and Mavor 2010; Martin 2006; Martin and Martin 2004). The first report of this work at a NEARA meeting (Martin 2001) led to the present study at "The King's Chamber", one of the largest chambers known to NEARA. The site is relatively near the Hudson River on Moose Hill in Fahnestock State Park, in the town of Putnam Valley NY.

The Hudson River chambers have been previously studied. The leading study of 97 chambers found 5 clusters of corbelled, slab-roof chambers about 3 miles apart. Each cluster had some 9-12 chambers, including one small mountaintop chamber facing SE, and a second larger highly placed chamber facing the

**Table 1.** GPS measurements (VV15 3/2/11-1, 3/7/11-2 gps.xlsx)

Location name notebook page	K1 953	R 953	C 956	K1 1124	W 1124	G 1124	Q 1124
North latitude (minutes) (a)	25.239	25.206	25.134	25.237	25.369	25.423	25.14
Northing (feet) (b)	1333	1132	694				
West longitude (minutes)(a)	47.355	47.627	47.495	47.367	47.610	47.628	47.59
Easting (feet) (b)	1384	143	746				
Azimuth (decimal degrees) (c)		260.8	225		305.9	313.5	239.9
Error (decimal degrees) (d)		+0.6	+1.0		+0.3	+0.6	+0.6
Error (decimal degrees) (e)		+1.5	+1.5	+1.5	+1.5	+1.5	+1.5

a) beyond 41 N or 73 W

b) as used in scaling the master map, computed using 6087 ft/min N-S, or 4565 ft/min E-W

c) relative to K1 location with GPS unit above chamber roof

d) computed using the typical GPS accuracy +- 2 meters at each end of the distance in question

e) estimated using 25' deviation of the two K1 points from their average

SW horizon. A correlation with the rising but not the setting winter solstice sun was suggested on grounds that the western-oriented chamber faced too far south (Trento 1978: 121-129). Other studies have done statistical compilations of chamber dimensions and orientation (Armbruster 1994; Cook 1998). The chambers are along the river streams (Midgley 2008). Occasional dolmens are found in nearby areas where streams of different rivers rise in close proximity (Midgley 2005, 2006).

Our first visit to the Moose Hill chambers showed that they follow Trento's pattern, with the smaller chamber facing SE and the larger one facing SW. They are constructed on either side of a ridge and each faces a nearby plaza area. A stream crosses to the south of both chambers and flows to the Hudson River by way of Peekskill Hollow Brook and Annsville Creek. A long ridge runs high on the opposite side of the stream to the height-of-land on the west forming an elevated horizon similar to the elevated land on two sides at Calendar I and on the east side at King Philip's Rocks. We were told of a large perched boulder on the ridge nearly due west of the large chamber and an open "terrace" area below the boulder. There is a standing stone recently erected just to the west of the entrance to the larger chamber<sup>1</sup>. After a first visit we resolved to explore the environment of the chambers, with particular attention to the astronomical significance of any stones along the skyline of the ridge that are visible from the larger chamber.

## SURVEYING METHODS

The initial survey method was through solar-oriented notebook mapping of landscape features such as the brook, roads and trails, and especially stone walls and large stones. The sun's direction and the time of day were recorded on each sketch together with paced radial lines from the survey point and between recorded items. The location and direction of 35mm photographs were entered as they were taken. Immediately after a day's visit, the sun's azimuth (taken from the U.S. Naval Observatory website) was recorded on each sketch and the bearing of each survey line determined. The azimuth and length of each segment, as well as identifying data on each segment and its end nodes, were within a week entered into a land surveying program (CartaLynx, from Clark University).

Over 13 visits filling some 100 notebook pages, a detailed map was accumulated which appears as a

welter of line segments, each described and linked to a notebook page in the accompanying data table. Nodes where segments join also are keyed to the data table, usually with some description of the node and a label printed on the displayed map.

This method produces a map which records the geometry of the stone walls and the qualitative nature of spatial regions in the landscape but, as distances increase, its accuracy fails. Accordingly the map was calibrated with four accurate GPS measurements, made with a government-surplus backpack instrument. Table 1 lists the four fiducial GPS measurements and their conversion to (x, y) coordinates on a rectangular grid. The procedure available in the Carta Lynx program was used to make a best fit of the corresponding points in the map to these fiducial points.

The final map is very detailed and best examined on a computer screen with zoom capability to enlarge any desired region. For this reason it was exported as a graphics file, loaded as a separate layer into a photograph editing program (Microsoft Picture-It), used as a guide for illustrations, and removed when the illustration was complete. Figure 1 is a simplified map of the Moose Hill area compiled in this way.

While the map can produce good estimates of the distance and direction between its items, it does not give elevations. Because setting astronomical bodies travel a sloped trajectory near the horizon, the elevation of the horizon affects the position of any stone such as a solstice marker that may be erected and it is important to measure elevations accurately. For this purpose a Keuffel and Esser engineer's transit was used; capable of reading minutes of arc with its vertical axis carefully oriented and its azimuth circle oriented by

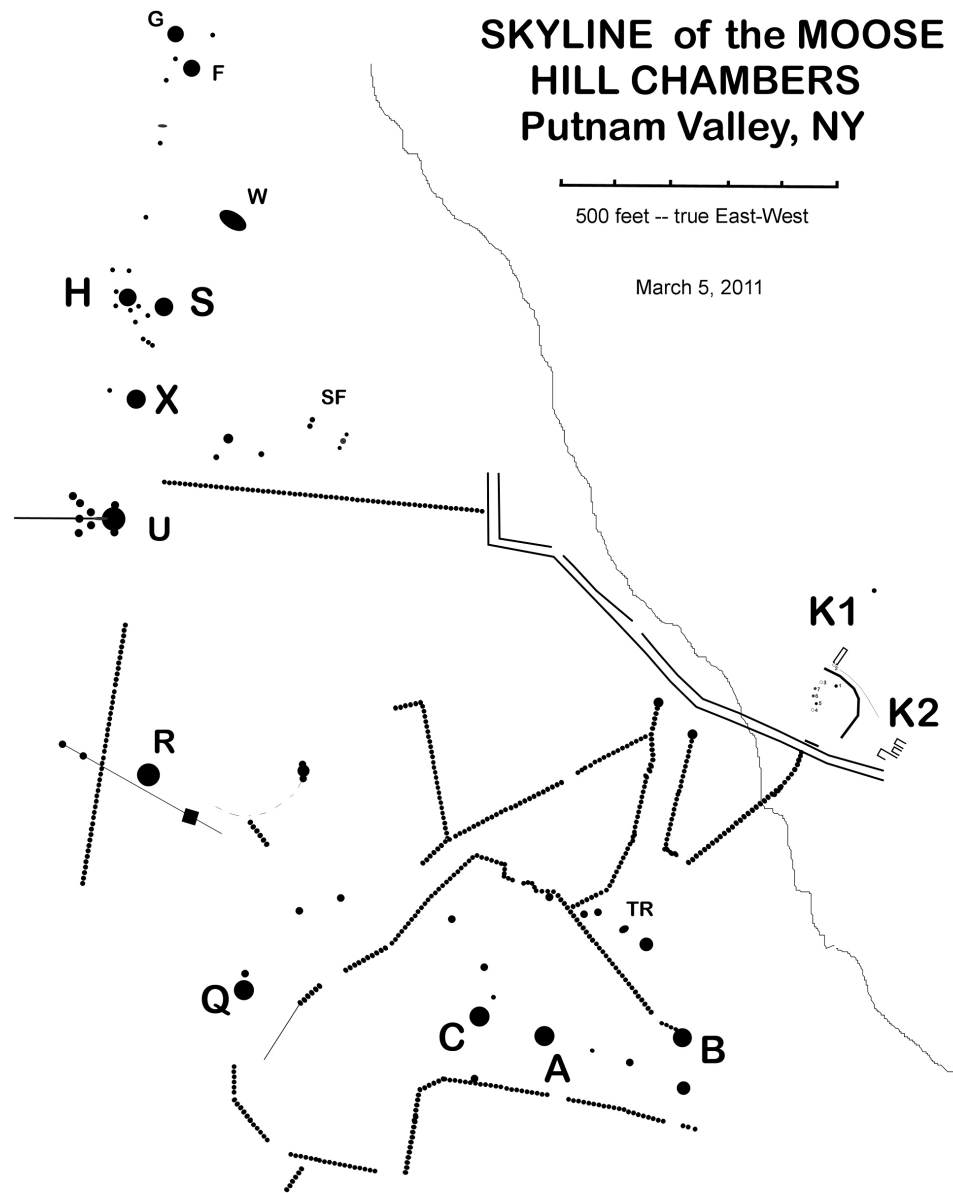

**Figure 1.** General map of the landscape near the Kings Chamber K1 and the small chamber K2, showing stones, stone walls, colonial roadway, and brook. A, B, C, Q, R, X, and S are large stones on the ridge opposite the chambers, which mirror signaling has proven to be visible from the plaza in front of K1.



**Figure 2.** The authors at rock R, with GPS unit and mirrors.

sun timing. In order to survey in spite of the heavy tree cover, the rodman and transitman reflected the sun at each other with two-foot handheld mirrors while talking on handheld radios. By starting at an intermediate distance and gradually working back to a distant object, distances as great as 1300' could be reached in spite of twigs and branches when no leaves were present. The mirror outline could be clearly seen in the transit telescope and adjustment could be made to inch accuracy at this distance. This method also proved that any skyline stone so investigated could actually be seen from the vicinity of the larger stone chamber without any intervening obstruction. Figure 2 is a photograph of the surveying crew with the GPS instrument atop stone R and the mirrors and notebook in the foreground.

Generally sunshots made just after setting up the instrument and again just before moving it to another station agreed with each other within an estimated rms error of  $\pm 5$  minutes of arc, both in the sun's azimuth and elevation, indicating that accurate measurements could be made of azimuth relative to true north and of elevation relative to a level horizon. Table 2 is a list of transit stations.

Because angle and elevation vary much more than the angular size of the sun or moon as the observer walks sideways or changes his height above sea level by walking down the sloped plaza, corrections had to be made from the transit position to any chosen observer's position<sup>2</sup>. Table 3 is a list of sightlines obtained in this way when the observer is in the plaza near the larger chamber at a point P3

chosen as described below. The transit was also used to follow sunsets, thereby determining the elevation at the base of the tree cover, as well as to survey the tree tops and various local items. Skyline surveys compiled in this way are presented in Figures 3 and 4.

**Table 2.** Transit Stations, specified relative to sighting point on left front edge of chamber door, 18" above floor.

station # name	1 bedrock	2 chamber	3 distant #1	4 distant #2	5 distant #3
line #	26		42	44	51
distance r to doorway from station	41' 3"	4' 1"	42' 5" (c)	94' 4"	66' 4"
azimuth to doorway (deg)	354.10	352 (d)	31.90	24.15	10.22
elevation angle h (deg)	3.28		7.72	7.35	6.96
relative telescope height (feet)	-2.4 (a)	+3.5 (b)	-5.7	-12.2	-8.1

a) calculated as  $r \tan(h)$

b) for transit height of 5' above chamber floor

c) length calculated from line #44 and distance 52' 6" between #1 and #2

d) calculated from measurements to each door jamb

Table 3. Sightline list (g)

name	Line #	page	sta conv		true Az (deg)	El (deg)	R (feet)	description	shift to	
			# (a)	# (b)					Az	El
									{decimal degrees}	
<i>Mirror-Surveyed sightlines</i>										
A	30	1123	1	3	219.67	7.05	821	poor sun, allow Az +/-1, El +/-0.5	221.04	7.16
C	17	953	2	4	226.25	7.02	881	to mirror 4 feet west of C	229.58	7.51
TR	4	940	2	5	218.07	1.05	576		223.33	1.91
TR	25	1114	1	3	222.03	1.78	576	right end	224.06	1.94
TRG	3	940	2	5	216.95	(1.30)	412		223.06	(0.26)
TRG	28	1115	1	3	221.07	(0.83)	412	right post height 5'4	223.87	(0.61)
TRG	29	1115	1	3	220.22	(0.80)	412	left post height 5'4	222.98	(0.58)
Q	21	961	2	4	240.75	8.08	1206	Az error +/-0.3 (poor sunshots); El above	243.60	8.44
Q	20	961	2	4	240.75	6.55	1206	El below	243.60	6.91
R	50	1722	5	6	263.6	9.1	1290	on center	263.89	8.88
X	43,46	1489	4	1	294.78	9.22	1384	6' above top of stone on center	293.39	8.88
HG	35	1448	1	2	296.30	7.38	1218	to tree on upper terrace below H or T1	297.48	7.46
HF	34	1448	1	2	296.25	7.33	1063	2' above northern stone of pair	297.60	7.42
W	22	1114	1	3	305.93	8.03	1388	chest height at vertical left edge of stone	306.85	8.10
S	40	1488	3	1	299.50	9.45	1408	3'4" below top of stone and 4' 10" south	300.13	9.38
<i>Derived Sightlines (d)</i>										
A'	17	1051	2	3	217.70		821	A to KC = 120'	220.80	
A	31	1123	1	3		5.93	821			6.04
U		1419	1		283.00		1334(e)	UX = 232'; Az +/- 0.5	284.19	8.80
H			3		298.45		1463(f)	S to KH = 26'	299.09	9.70
B					202	4.8	664	estimated from pacing map	204.74	9.70

- a) stations as numbered in Table 1
- b) book and page for conversion to true azimuth using sunshots: 1-VV14 3/25/09-1; 2-BB7 1451; 3-VV8 12/14/05-3; 4-VV5 3/23/04-10; 5-BB5 944; 6-BB8 1725
- c) as obtained by coordinate measurement on final GPS-sized map VV14 4/7/09-3
- d) derivations at: A- VV6 5/26/04-1; U,H - VV15 3/4/11-1
- e) elevation interpolated from Fig 4.
- f) elevation taken same as S
- g) original at VV sum 3/9/11-2a or sl7.xlr

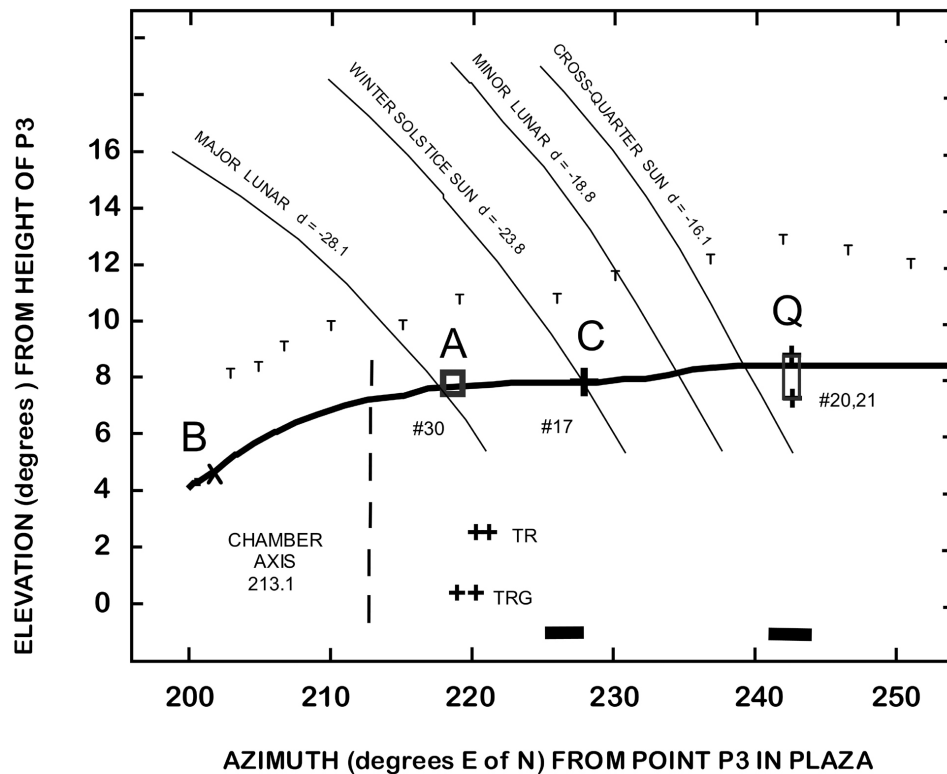

**Figure 3.** The southwest skyline seen from point P3 in the plaza in front of the Kings Chamber K1. Symbols A, B, C, and Q represent the transit-surveyed azimuth and elevation of stones, the dark line is drawn to guide the eye, and T shows the surveyed treetop elevations. The calculated trajectories show that the winter solstice sun sets behind C, and that the moon sets near A at 18.6-year intervals. There are no large skyline stones near the trajectories for the southern cross-quarter day or the southwest minor standstill. The horizontal bars show azimuths of C and Q from Table 1 as calculated from GPS readings and shifted to P3. The dashed line marks the center of Figure 11.

For comparison the trajectories of the sun and moon at various times are shown in these figures. A first look at the skyline profile does suggest that the stones have an astronomical use: R for the sun at two annual equinoxes, Q, U at the four annual cross-quarter days, C, X at the two annual solstices, and A, H for the extremes of the moon, which occur at 18.6 year intervals. However as will be described, the varying nature of these markers, the position of Q, and the similarity of X to S lay doubts on this simple interpretation.

### SOLSTICES AND EQUINOXES

The transit surveying to about  $\pm 0.1^\circ$  enabled determination of the position and elevation of the mirror near a particular stone to about  $\pm 2$  feet (perpendicular to the sightline). The master map near the accurately surveyed points was corrected according to this information. We then hypothesized that the crossing point of sunset shadows of these accurately located stones would indicate an important presumed observation point.

Working first with the shadows of stones C and X one can determine an east-west line of points at which the solstice shadows intersect. Position along the line measures time, since the azimuth of sunset varies by about 0.1 degree per millennium. The line falls about 75 feet south of the larger chamber in a sloped "plaza" area. The plaza has a knoll behind it with an encircling wall of long stones in and on the steep slope of the knoll.

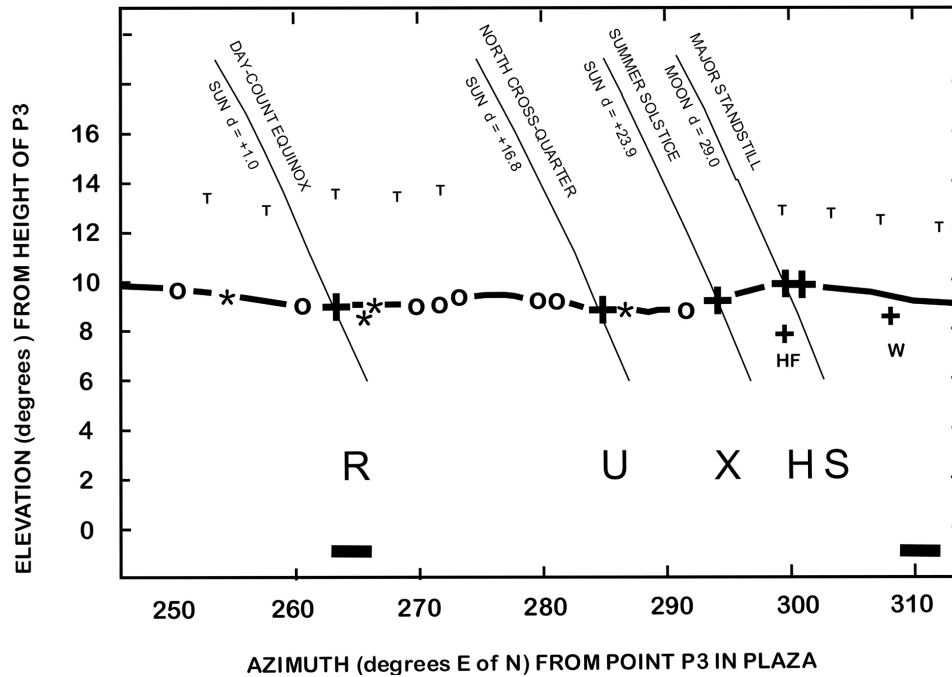
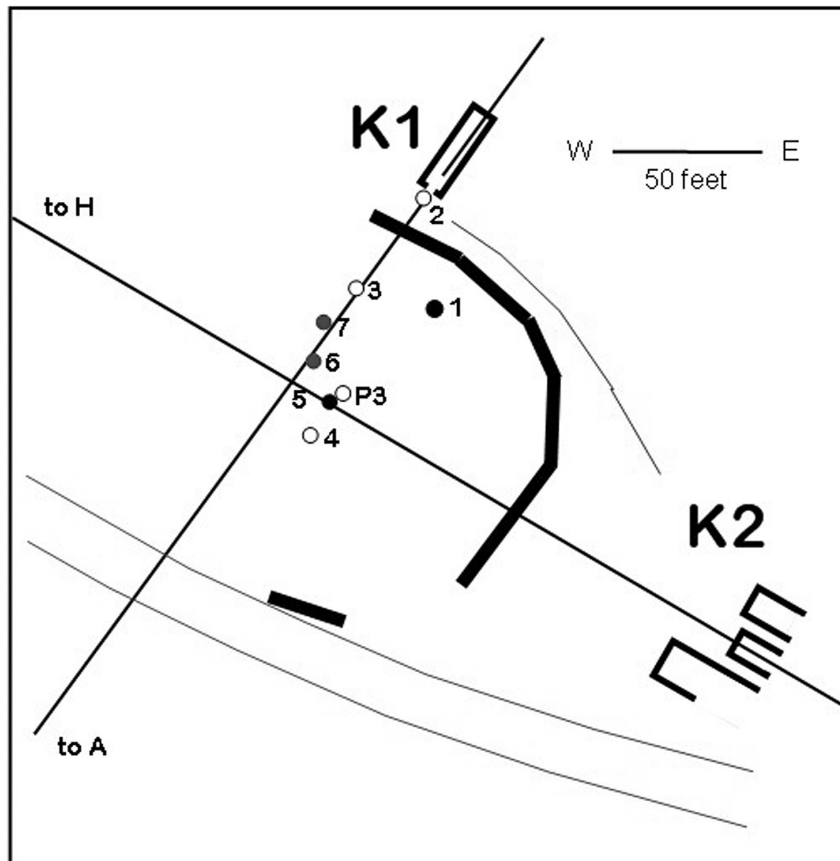

**Figure 4.** The northwest skyline seen from point P3 in the plaza in front of Kings Chamber K1. Asterisks show transit observation of the setting sun at the horizon; symbol O denotes transit observation of sky seen through the base of tree cover, and T again shows surveyed treetop elevations. Symbols R, U, X, and S represent prominent rocks; H is a fallen slab. X matches the summer solstice sunset, and R matches the day-count equinox halfway between the solstices.

To determine shadow direction, graphs of the azimuth and elevation of the sun at the solstices were used. The shadow azimuth was read off according to the elevation, an iterative process P1, P2, P3 because the plaza slopes some 20 feet in height, causing variation in the elevations. The line from C, the winter solstice marker, crosses with the line from X, the summer solstice marker, near a point P3 in the plaza region in front of the large chamber, when an ancient declination of 23.9, corresponding to 2000 BC, is used for the sun. This discovery caused us to map the curved arc of large stones beginning near the larger chamber, which surround P3 at a nearly constant distance of some 60 feet as shown in Figure 5. We also examined the ground near P3, and found what looks like the tip of a buried stone and a 4' flat flagstone between P3 and the chamber. The central nature of P3 suggests that the sloped area in front of the larger chamber may be a very ancient "plaza" used for observation. However if a modern declination of 23.5 for the return sightlines is used, the crossing moves away from the center of the arc to a point P4 at about 30 feet east of P3, more than our estimated surveying error.

Any two rocks can produce crossed sightlines, so the third shadow from R needs careful study. Initially a declination of +1 for R was estimated from Figure 4, a value consistent with an ancient practice of determining the equinox by counting half the days between the solstices. This "day-count" or "megalithic" equinox has been noted in the American southwest (Malville 2004:143), and differs from the modern equinox when by definition the sun rises due east and sets due west with declination zero.

To confirm this finding more accurately, a program of trigonometric computations was written to compute the declinations that would be seen for C, R, and X from an observation point anywhere in the plaza, based on the azimuth and elevation measurements from the various actual transit locations. It showed that the shadow from R misses P3 in ancient times, thereby disqualifying P3 as an ancient observation point.



**Figure 5.** Surveyed map of the "plaza" area, showing the semicircular arc of long stones, the two chambers, the colonial road, and lines drawn to the two possible major standstill markers A and H. A possible walkway exists from K1 to K2 behind the long stones. Symbols: 1, 2, 3, 4, transit stations of Table 2; 1, 5 bedrock outcrops; 6, tip of buried stone; 7, 3-foot flat stone; P3, central point to which surveys 1-4 are shifted.

In detail, although C and X have Archaic declinations of -24.0 and 23.9 (approximately 3000 BC) as viewed from P3, R has a declination of 1.3, nearly a full degree from the day-count equinox in Archaic times<sup>3</sup>. However the shadow from R falls on P4 as best we can tell, suggesting that the day-count equinox was observed in Woodland times. In detail, for an observer located 67 feet from the left edge of the chamber doorway at a bearing S02W (approximately at P4), the declinations for C, R and X were -23.5, +1.2 and +23.4 respectively. The declination 23.4 corresponds to Woodland times near 1000 AD, and the declination 1.2 compares to the Woodland equinox value of 1.0

The value  $d = 1.0$  represents a limit, because it is the largest value allowable for the day-count equinox in modern or Woodland times<sup>3</sup>. The difference of 0.2 degree from this limit can be attributed to our experimental error of about 0.1 degree for each measurement, with a random variation as large

as 0.2 degree for the difference of two measurements. Also rock R is some 4 feet wider than C or X, and viewing sunset at the side of the rock rather than at its top would induce an 0.1 degree error.

It may be concluded that our measurements are consistent with modern equinox observations, but that they do not rule out observation of the two solstices and a day-count equinox in Woodland times from a single point near P4. Archaic viewing would be possible from P3 at the solstices, but the viewer would have to move many feet northwards closer to the chamber to view the sun over R at the day-count equinox in Archaic times.

In addition to astronomical inference of the importance of skyline stones C, R, and X, further inference may be made by direct local observations. Indeed inspection of the surroundings of stones R and C does also suggest their importance as centers of activity. The density of stones surrounding them contrasts with a paucity near stones A and Q.

In more detail, 8-foot-tall stone C has a north stone of comparable size located 22 paces north of it, and a south stone 22 paces south of it, so that the three stones in a line define the prime meridian. To its northwest at a distance of 14 paces there is a small "terrace", meaning an area which seems to have been flattened and set apart from the surrounding soil. It is about 14 paces away at a bearing N 40 W, and has a rectangular shape 2 paces x 1.5 paces. It is bounded by a 6' long by 2' wide stone slab on the edge near C, some large



stones and a bedrock knob on the downhill side, and irregular stones on the two remaining sides. Its location would be suitable for viewing the rising trajectory of the winter solstice sun over stone C. Another rectangular array of stones lies 5 paces west of C. Finally, downhill of C on a line in the direction of the large chamber is a stone, followed by a pair of cairns on either side of the line in gateway fashion, followed by a second larger gateway made by the north stone 4 paces to the left and a drystone cairn 4 paces to the right. The hilltop surrounding C is also bordered on all sides by rock face, cliff, or stone wall, as can be seen in the map. An interesting feature is the inclusion of quartz stones in the northwest wall, and a gate with quartz in both of its pillars leading out along the ridgetop toward stone Q, suggestive of night usage. Overall this reading of the landscape around stone C suggests that it was indeed important as a winter solstice sunrise marker.

Stone R is a 10' egg-shaped stone perched on chocking stones which prevent it from rolling down a steep bedrock escarpment toward the chambers. The area near R is intersected by a narrow stone wall which from its straightness over an extreme length appears to be an historic period boundary wall. However in the hollow below the escarpment and beneath the direct sightline from R to the chamber there is a second "terrace." It is a level area some 5 paces across, bordered by three 6-foot-diameter heaps of small stones. During a spring visit it had 6-inch green grass, definitely different from typical leafy brown color elsewhere. From the ridge adjacent to this flat area, a 4'-wide walkway ascends on a curved path toward R, reaching a remarkable drystone gateway between a bedrock ridge on the right and a wide drystone wall on the left. A person standing in the gate looks directly at R. In addition to the "terrace" below R, there are two nearby stones R1, R2 on the high ridge. Preliminary estimate says they define a direction E30S toward a large stone cairn on an opposing shoulder of the ridge. These stones may be suitable for sighting on the winter solstice sunrise, since the eastern stone R1 has a flat, nearly vertical face which can be viewed edge-on from the western one R2. Overall the complex near R, like the enclosed rectangle and downhill cairns near C, gives the impression of a ridge-top ceremonial area.

### THE EQUIVOCAL NORTHWEST MAJOR STANDSTILL

The process of laying out a return shadow line was repeated for the presumed major lunar standstill markers, but the results depend on the markers chosen. If H is chosen as the north major standstill stone, the return sightline from A crosses the return line from H at a point that may be labeled M1. The distance of 11 feet between P3 and M1 is reasonable, considering errors of +4 feet from each return shadow line and the possibility that different edges of the sun and moon were used in sighting. However H is an equivocal marker. It is a slab of stone that might once have been erected from glacial remains, surrounded by stones of nearly equal size. We prefer to classify stone H as equivocal evidence, on grounds that it is too small to be presently seen from below. An archaeological find, showing that H once had chocking stones to support it, could disprove this opinion<sup>4</sup>. If instead of H the highly visible stone S is selected as the north major standstill marker, the return line from S crosses with the one from A at a point M2 about 30 feet north of P3, far enough for us to say that M2 is separate from P3. Possibly the observation point was moved.

The uncertainty in assignment of S and H allows only speculative arguments for observation of the northwest major standstill. However, as illustrated in Figure 5, it is interesting that the two stones in the ground near P3, as well as the complex at TR to be described below, are approximately on what may be a southern major standstill line from A through P3 to the larger chamber. Point P3 is also approximately on what may be a northern major standstill line from H to the smaller chamber K2 and thence outward to the southerly extremes of moonrise. The crossing of these two directions near the center of the curved arc of stones suggests an original early architectural plan for the area. Possibly the site was begun in Archaic times by hunter-gatherers with a lunar tradition, who had no interest in solar equinoxes, and was later modified by agriculturalists<sup>5</sup>, who were responsible for stone R.



**Figure 6.** Photo of small chamber, showing fallen lintel across its entrance, in need of repair. The arc of long stones is located on the other side of the ridge visible in the background.

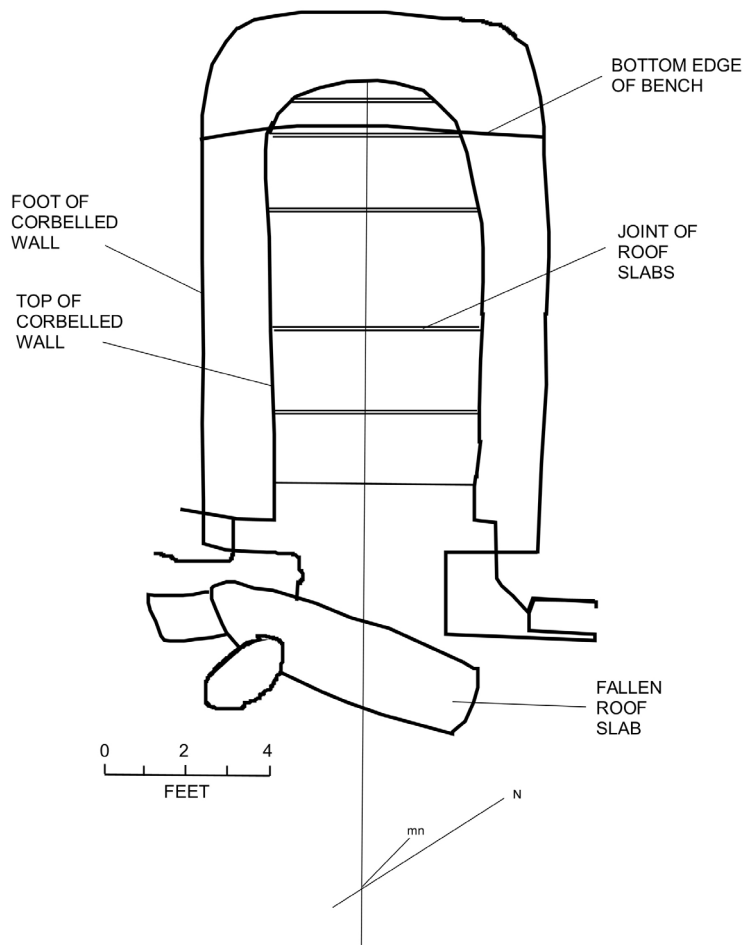

## THE TWO CHAMBERS

As just mentioned, there seem to be lunar sightlines which end at the two chambers. Some description of the nature and orientation of the chambers themselves will thus be made, followed by a speculative interpretation.

A photograph of the smaller chamber is shown in Figure 6, and a measured plan made by transit-oriented steel-tape survey is shown in Figure 7. The smaller chamber has a shelf or bench at its rear, similar to chambers<sup>6</sup> elsewhere in Algonquian territory. The walls, spaced 8' apart, are vertical for 2' 4", but then are corbelled for another 3' 2", with roof slabs closing a gap of 5' 2" at the top. As in the larger chamber, the corbelling stones are shaped so that their outer surface conforms to the sloped wall while the joints between stones are level. The smaller chamber faces two distant hills on the horizon -- Barrett Hill, which a skyline survey indicates coincides with the winter solstice sunrise, and an unnamed hill<sup>7</sup>, which coincides with the minor lunar standstill. The chamber is too short to indicate an accurate direction. By direct observation at the winter solstice sunrise the sun was seen to shine on the back wall of this chamber.

A photograph of the interior of the larger chamber is shown in Figure 8, and its measured plan in Figure 9. Examination suggests that the larger chamber has been extended in length and improved with a new doorway<sup>8</sup>, perhaps after the nineteenth-century roadway and its bridge across the brook were constructed.

**Figure 7 (left).** Plan of small chamber, measured with steel tape and solar-oriented transit. Axis 122.3 deg. Above a height of 2' 4" the walls are corbelled inward, supporting 6 roof slabs. The rear of the chamber has a bedrock stone bench.

This later activity did not alter the direction of the existing chamber. The larger chamber has a dirt floor. Stone chambers in Vermont are known to have either bedrock or flagstone floors (Mavor 1989:22) and excavation to find what is under the probable flagstones of this chamber might result in archaeological proof of its age.

The larger chamber faces across the brook to a relatively level hilltop some 900' distant. Many compass measurements of its orientation have been made, differing by as much as 5 degrees. The walls expand by 16 inches at the rear and the trend line of our steel-tape measurements to the walls of the chamber is uncertain by about +3 inches in 33 feet; meaning that its axis is determinable only to  $\pm 0.4^\circ$ . By measurement to lights held at the two rear corners from a solar-oriented transit centered outside the door, we find  $213.6^\circ$ , and since the door is off center by 5 inches, a direction of  $213.1^\circ$  for the chamber axis. This is considerably further south than the setting point of the winter solstice sun at  $229^\circ$ , a fact proved by direct observation -- the last rays of the setting sun reach back only 24' 6" on the southeast wall of the 33' long chamber.



**Figure 8.** Interior photo along axis of large chamber, showing corbelled walls and roof slabs.

What could have been the use of this direction? This question may be addressed by considering the map of Figure 1, which suggests that it leads to an observational center on the opposite side of the brook from the chambers. In the direction of the chamber axis beyond the chamber plaza and on the other side of the roadway, there is a gentle slope down to the brook and then what seems to be a graded roadway ascending between two converging walls which comes to a gateway TRG. The gateway opens into a semi-enclosed area below a long straight stone wall ending at a huge boulder B. In this area, still on the line from the large chamber is a rock cluster TR (for "Turtle Rock"). As shown in the photograph of Figure 10, it is a slab

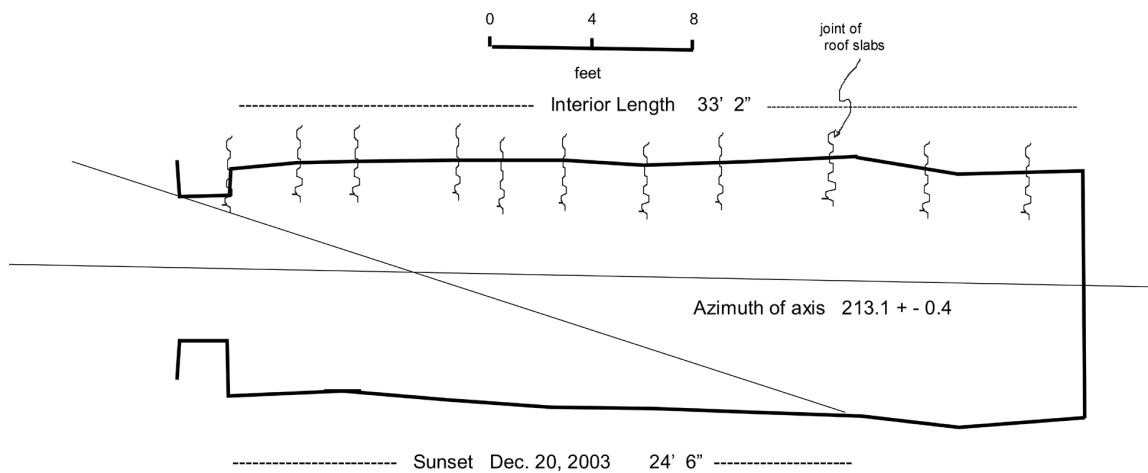

**Figure 9.** Plan of large chamber, measured with steel tape and solar-oriented transit. The diagonal line shows the edge of the shadow cast on the floor by the winter solstice sunset.



**Figure 10.** Photograph of Turtle Rock. Camera facing southwards.

propped on a base having a resemblance to a turtle, bearing a superficial resemblance to 20 other clusters, called rock shelters, which give evidence for continued use from Archaic into Woodland times (Dudek 2004). Directly west in the corner of stone walls are two stones and 12 paces to the east is a 20-foot flat-topped rock suitable for use as a stage platform with a drystone construction at its uphill side. There is a second pair of parallel stone walls aligned on TR which ascends the slope and passes through a wider gateway. Possibly they are the access to a pasture from the nineteenth century roadway. Alternatively, their bearing of about N12E as seen from TR could derive from an interest in the stars of the Big Dipper. This bearing shares maximum frequency with the summer sunrise in a histogram of orientation of prayer seats in New England (Ballard 1999:Table I). TR itself has a view of the eastern horizon and points at a bearing of about N66E where the sun rises in summer.

### THE SOUTHWEST MAJOR STANDSTILL

Accurate surveying also seems to indicate a lunar connection between the large chamber and TR because TR lies under the setting point of the most southerly possible moon. Figure 11 is an illustration combining the measured dimensions of the chamber with transit measurements. It shows the elevation of the opposite hill and its tree line outside the chamber door together with the trajectories of the major standstill moon and the winter solstice sun, as viewed from a point at floor level at the center of the rear chamber wall<sup>9</sup>. Transit measurements to the gate TRG, to the rock shelter TR, and to stone A have been added<sup>10</sup>, which indicate that TR lies under the setting point of the most southerly possible moon at stone A.

It can be seen that the axis of the chamber does not exactly line up with TRG, TR, and A, so that a better viewing point for the moon on a cleared horizon would be obtained from a location in the plaza slightly to the right of the chamber axis. However the axis does line up with the most southerly possible moon setting over the trees of the opposing hillside, an event that occurs on an 18.6-year cycle. If a summer solstice ceremony were involved, the full moon would have illuminated the chamber floor. Alternatively illumination might have been sought in days near the winter solstice, when the most southerly possible new moon seems to die with the setting sun, and then to be reborn again a few days later.

As a further aside, it is interesting to speculate how lunar timing may have been associated with use of the chamber. Collective burial is a possible ancient use of the Hudson River chambers (Trento 1978:129). The fact that they are presently empty is not determinative; for example in Ireland only a few of the 1200 wedge tombs dating to 1500 BC (deValera 1961:108, 115) still contain human remains (deValera 1982:112, 110). In Late Archaic times, it seems that the groups of the Eastern woodlands, who ranged over great distances between the major river valleys in search of food, used bundles that were "easier to carry over long distances to burial grounds" (Milner 2004:53). The custom of bundle burial is in fact found to survive as late as the Late Woodland period in New England (Waller 2010).

Collective burial may also be associated with the moon. In Scotland there is a region where the inhabitants built the Clava cairns, which have small passages aligned from the central crypt to the setting points of the moon at its major standstills (Burl 1981). Regionally, there is also a possibility of lunar timing by the 9.3-year interval between major and minor standstills. In the service of immortality for the ancestors,

"East of the Mississippi nearly every nation was accustomed, at stated periods -- usually once in eight or ten years -- to collect and clean the osseous remains of those of its number who had died in the intervening time, and inter them in one common sepulchre, lined with choice furs, and marked with a mound of wood, stone, and earth." (Brinton 1896:278). The famous Smithsonian report, denying that American mounds were built by lost races of Europeans, collected earlier reports of the 8 to 10 year interval in support of its argument that collective burial was a common indigenous purpose of mound-building (Thomas 1891:657).

Thus the orientation of the chamber could possibly relate to allowing the spirits of the ancestors, carefully preserved in communal burial, to travel into the heavens in a particular direction at a particular ceremonial date

**DISCUSSION OF THE SKYLINE STONES**

The remarkable coincidence illustrated in Figs 3 and 4, between well-separated large stones visible on the skyline and astronomical directions, may turn out to be just that -- pure coincidence. In this section we will discuss three hypotheses, and suggest how archaeological work might verify one of these models.

**Consideration of a Four-Part Year**

Consider the hypothesis of a 4-part year, with observation of the sun at the solstices and equinoxes. At one solstice, we calculate the known direction of the sunset and ask whether a stone can be observed on the horizon in that direction. Suppose that a melting glacier deposits a stone, and that the observer walks around the plaza looking in the chosen direction. The probability of finding a stone in the chosen direction depends on the density of stones along the horizon. Noting that the distance between large stones positioned by the supposed glacier seems to be around 500 feet, and that the width of the plaza is about 100 feet, it can be estimated that there is about a 20% chance of the observer's search happening to intersect a stone. For the other solstice, the glacier independently deposits a stone and the observer looks in a different fixed direction as he walks around, and the chance of intersecting a stone is again 20%. The same is true in the equinox direction. However the chance of obtaining all three intersections from somewhere in the plaza is  $0.2 \times 0.2 \times 0.2 = 0.008$  or 1 in 125. In other words, there is only a 1% chance of false match to the model of human placement to mark a 4-part year.

However probability does not prove cause. One may get a false result of a statistical test, and therefore be allowed to discard the test pending further investigation. More accurate surveying of distances and stone profiles might enable a reanalysis based on Table 3. However on present evidence we feel that the arrangement of stones in the flat area surrounding the possible winter solstice stone C gives it a different style from the precariously perched egg shapes of R and X. Although C, R, and X are of approximately equal size,

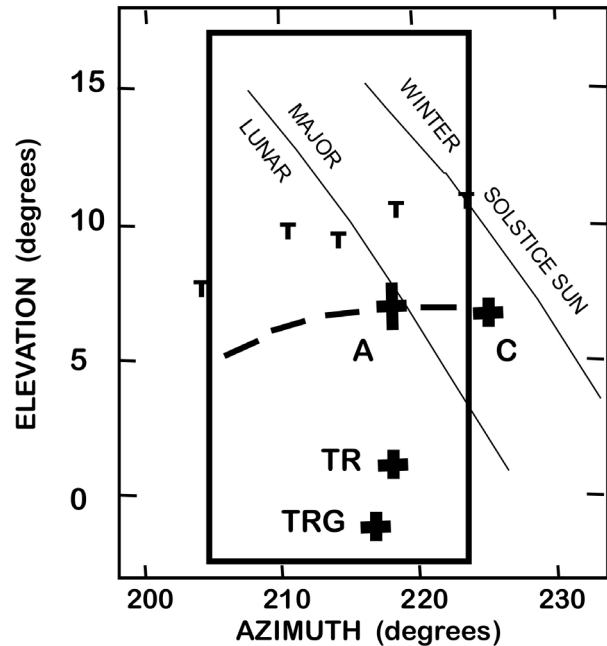

**Figure 11.** Outlook from the rear of the large chamber, showing that its axis of 213.1 degrees points in the direction that the most southerly possible moon sets over the opposite ridge (at an 18.6 year interval). The dark rectangle is an estimate of the outline of the original doorway as explained in the text. TR shows the location of the rock shelter on the opposing hillside, and TRG the intermediate gateway. A and C denote skyline stones.

their surroundings are not unequivocally similar, and thus lines from the plaza do not satisfy Burl's test of "a single-phase monument in which there are several unequivocal sightlines" (Burl 2000:59). Archaeological investigation of the ground near stone C might prove human construction and thereby bolster the hypothesis of winter solstice observation in the 4-part year.

### **Cross Quarter Days Fail**

An 8-part solar year based on 3 stones marking a 4-part solar year together with 2 interior stones marking cross-quarter days was identified in England (Thom 1967:Fig. 9.2). Near the stone chambers of Calendar I, where the stones are chocked in green soil laid down just after the glaciers, Mavor and Dix did find a southern cross-quarter stone on Dairy Hill (Mavor 1989:27), suggesting that another ancient site in New England might have them. If the hypothesis of an 8-part solar year could be proven, the chance of intersecting 5 randomly placed stones is still smaller, namely 1 in 3125. However the hypothesis fails at our site, because stone Q is too far north to match the southern cross-quarter day, although stone U does fit well to the northern cross-quarter day.

It makes more sense to speculate that these two stones may have had individual uses. U itself is an obvious 10' rounded boulder with a north-south axis, located at the top of the eastern slope. There is a sloped, open space between U and the cliff at the western side of the ridge. A low stone wall leads away from U in a due west direction, about halfway to a pair of 5' stones that frame the view over the cliff to the horizon. Because of the high location on the top of the ridge, there is a panoramic view of the western horizon from U. It could thus possibly be a place for watching the equinox sunset after it has ceased to be visible behind stone R.

Stone Q on the other hand is a 10' squarish slab on bedrock suggestive of a glacial deposit. Its flat face lies in a vertical plane, somewhat like stone R1. The plane intersects the ground in a line pointing at about azimuth 63, which is almost exactly the minor standstill. Q is also outside a gate with white quartz stone markers at each side, located in the drystone walling which surrounds the hilltop containing stones A and C. It could possibly be a place for watching the monthly southern moonrise limit during the minor standstill, of importance in starting the 9-year period to the next major standstill.

### **The Northwest Major Standstill is Equivocal**

We also can test a 5-stone hypothesis of 3 stones marking a 4-part solar year together with two exterior stones marking the 18.6-year lunar cycle. This essentially fails, because stones H and S do not generate confidence in the idea of northern setting lunar observations, H because it is visually unremarkable as it appears at present, and S because it would require a questionable observation point separate from the solar observation point. The lunar part of the hypothesis is supported mostly by the southern arm K2-TR-A. Also, even though stone A is above TR as seen from the large chamber, it is less likely to be a marker than C or U because, with the exception of one stone cairn, it has no definite human construction nearby.

## **CONCLUSION**

We feel that the evidence from the architectural ground plan suggests that the chambers may be older than colonial. Features, which seem unlikely to be constructed for European-influenced reasons, include: the semicircular arrangement of long stones around a plaza in front of the larger chamber; an apparent line of sight from the larger chamber across the plaza and then through a stone gate to a prominent rock (which would be described as a rock shelter in other contexts); stone walls that enclose a hilltop, including a gate marked with 6" white quartz blocks; and lastly an open plaza which connects upwards through a carefully made stone gate to one of the largest stones on the ridge.

In seeking to test the hypothesis of astronomical sightlines, we find three stones (at winter solstice, summer solstice and equinox sunset positions) suitable to fit a 4-part solar year. The estimated probability

of glacial placement of stones simultaneously in these three directions is around 1% , based on the distance between the stones on the horizon and the size of the plaza. However, as probabilities do not show mechanisms of causation, we prefer to suspend judgment on the idea that human construction is probable even in the face of this daunting number.

The primary reason for suspending judgment is the heterogeneous nature of the skyline stones. Although the chambers and the semicircular arc of long stones are certain, the site fails Burl's criterion of "a single phase monument in which there are several unequivocal sightlines," because the distant markers are heterogeneous and therefore equivocal. However we note that the precariously perched egg-shaped stones could represent the improvement of a very ancient site if the site developed in several phases over time.

We conclude that the character of the stone remains which surround the Moose Hill chambers suggests pre-contact construction and that therefore the plaza, some of the skyline stones, and the chambers themselves deserve detailed investigation by subsurface archaeological techniques.

## NOTES

<sup>A</sup> The authors are individual members of the New England Antiquities Research Association, a nonprofit group interested in above-ground stone structures primarily in New England. NEARA provides a discussion forum for its members, without any implied endorsement of their opinions. It encourages mapping, photography, and preservation, and its ethics statement forbids excavation.

<sup>1</sup> The boulder and the remains below it were described to us by Martin Brech, former NEARA coordinator for New York. He also stated that he and others had erected the fallen standing stone in what they believed was a remaining socket for it.

<sup>2</sup> The Microsoft Works spreadsheet used to compile Table 3 was programmed to do the trigonometric calculations required to find the azimuth, elevation, and length of the line from the old transit location specified in Table 2 to the new observing location, and then to find the change in azimuth and elevation of a stone as observed at the new location. To simplify the second step, it was assumed that the distance R to the stone (measured from the old location on the map) was the same at a new location, an approximation that produces negligible error in the computed change, since R is large. Elevation angles were corrected by the difference in heights between locations, divided by R and converted into degrees.

<sup>3</sup> By programming the expression for the mean anomaly of the sun (Thom 1967:24) we find that the modern sun's declination on the day halfway between the solstices is about +0.7 in the spring and +1.0 in the fall, with a decrease of about 0.1 degree per millennium in both cases for many millennia earlier than 1000 AD.

<sup>4</sup> We have recently found what might be classified as a lunar gateway which, if carefully surveyed, might serve as additional evidence. It is shown at location SF in Fig 1, approximately in line with stone H, on a high intermediate ridge and thus possibly at the skyline. It consists of a small, shaped standing stone in the center with stones serving as gateposts located 3 paces on either side, with a small plaza located 20 paces below it, somewhat similar to the plaza below R.

<sup>5</sup> The traditions of such people might also account for stone B. The importance of this boulder is suggested by the long straight wall which leads to it, by the segment of wall which leads the eye to it from the chamber area, and by the gateway leading to this wall from the chamber plaza. With a bearing S25W it is similar to the 3-stone row on the unnamed hill of note 7, and to other southern-facing outlooks such as two southern stones on the map of Oley Hills PA. It lies further south than the moon ever travels, and if it is an astronomical marker it must be for a star. Ancient Algonquian belief included a giant serpent in the land of the dead, seen in the southern sky in summer near the star Antares (Lankford 2007: 208, 254). Because of the rapid changes due to precession, it is not possible to determine whether this direction matches Antares without a radiocarbon date for the plaza.

<sup>6</sup> Stone shelves were noted during NEARA-sponsored visits to slab-roofed stone chambers located in Hardwick MA 01031, where compass measurements indicate that the winter solstice sunrise shines through the entrance onto the rear wall and its bench, and in Oakdale, CT 06370, where the shelf is on a side wall and motion picture photography shows that the winter solstice sunrise shines onto a white stone at the bottom right side of the rear wall. These chambers are listed in the NEARA inventory.

<sup>7</sup> This hill was explored and found to consist of a bedrock ridge with three large boulders on it running for some 136 paces in a direction about N 35 E, similar to directions indicated by stone remains at Newfane, VT and Hardwick, MA, directions possibly of interest to the Algonquians as they followed the Great Bear constellation, or the winter zenith arch of the Milky Way. The boulder at the north end is close to a remarkable 5-foot table dolmen perched on 4-inch stones near a cliff with outlook to the northwest, while the largest boulder located at the south end is also the center stone in a secondary row of three in the direction N 32 W.

<sup>8</sup> Like the sun, the moon cannot shine all the way to the end of the existing chamber because the door lintel is in the way. However as already mentioned the chamber appears to have been lengthened. The NEARA survey (Armbruster 1994; Cook 1998) indicates that most chambers were built with a smaller length-to-width ratio, so in the original chamber the moon may have illuminated the entire chamber floor. A shorter length widens the angle subtended by the doorway from the back of the chamber. In Figure 11 (see page 159) an estimate of the width and height of the original doorway has been made by shifting the present doorway 16 feet to the rear.

<sup>9</sup> The large chamber could possibly have served as a storeroom for a sawmill located on the brook adjacent to the colonial roadway. Such mills were common in rural New England and the existence of one is likely because of two concrete sluiceways in the brook nearby for an undershot water wheel, and the remains of what looks like a large stone dam upstream of them. The mill must have been abandoned sometime after the replacement of stone by concrete as a construction material in the latter part of the 19th century. The county atlas of 1868 shows a road up the long valley, and the absence of all but a few houses.

<sup>10</sup> The shift  $a$  to azimuth  $A = At + a$  was calculated using the formula:

$$a = (180/\pi)(r/R) \sin (At - Ao)$$

where  $\pi = 3.14$ ,  $r$  and  $Ao$  are the distance and azimuth from the transit to the new observation point, and  $R$  and  $At$  are distance and azimuth from the transit to the item in question.

## REFERENCES

Armbruster, Paul D.

1994 Unpublished data tables on measurements of chambers, 33 columns, 60 rows, dated 10/23/94. NEARA archives, NY chapter, and NEARA files, NH Technical Institute Library, Concord, NH.

Ballard, Edwin C.

1999 For Want of a Nail: An Analysis of the Function of some Horseshoe or "U"-shaped Stone Structures. *Bulletin of the Massachusetts Archaeological Society* 60(2): 38-54.

Ballard, Edwin C., and James M. Mavor

2010 A Case for the Above-Surface Stone Constructions in a Native American Ceremonial Landscape in the Northeast. *Bulletin of the Massachusetts Archaeological Society* 71(1): 8-26.

Birmingham, Robert A., and Leslie E. Eisenberg

2000 *Indian Mounds of Wisconsin*. University of Wisconsin Press, Madison, WI.

Brinton, D. G.

1896 *The Myths of the New World, a Treatise on the Symbolism and Mythology of the Red Race of America*. 3rd ed., Philadelphia, PA D. McKay

Burl, Aubrey

1981 "By the Light of the Cinerary Moon," Chambered Tombs and the Astronomy of Death. Pp. 243-274 in *Astronomy and Society in Britain during the Period 4000-1500 BC*, edited by C. L. N. Ruggles and A. W. R. Whittle., British Archaeology Reports #88, Oxford.

Burl, Aubrey

2000 *The Stone Circles of Britain, Ireland and Brittany*. Yale U. Press, New Haven, CT.

Cook, Thad

1998 (appx date.) Unpublished data tables of measurements on chambers, 15 columns x 37 rows. NEARA archives, NY chapter.

Dix, Byron E.

1975 An Early Calendar Site in Central Vermont. *Epigraphic Society* 3, no. 51.



- Dix, Byron E. and James W. Mavor, Jr.  
1981 Two Possible Calendar Sites in Vermont. In *Archaeoastronomy in the Americas*, edited by Ray Williamson. Ballena Press, Los Altos, CA.
- deValera, Ruaidhri, and Sean O'Nullain  
1961 *Survey of the Megalithic Tombs of Ireland*, vol I. Government Publications Sale Office, Dublin  
1982 *Survey of the Megalithic Tombs of Ireland*, vol IV. Government Publications Sale Office, Dublin
- Dudek, Martin G., and Craig S. Chartier  
2004 The Tall Pines Rockshelter, Clinton MA, and Rockshelter Use during the Late Woodland and Contact Periods. *Bulletin of the Massachusetts Archaeological Society* 65(1), 18-24.
- Feldman, Mark  
1977 *The Mystery Hill Story*. Mystery Hill Press, New Haven, CT.
- Fowler, Melvin L. and E. C. Krupp  
1996 Sky Watchers, Sacred Space, Cosmology and Community Organization at Ancient Cahokia. *Wisconsin Archaeologist* 77(3/4): 151-158.
- Hitching, Francis  
1978 *Earth Magic*. Pocket Books, New York. (Reprint, original 1976, William Morrow, U.K.)
- Lambert, Joanne D.  
1996 *America's Stonehenge, an Interpretative Guide*. Sunrise Publications, Kingston, NH.
- Lankford, George E.  
2007 *Reachable Stars, Patterns in the Ethnoastronomy of North America*. University of Alabama Press, Tuscaloosa AL.
- Leonard, Kenneth C., Jr.  
2010 Identification and Preliminary Analysis of a Late Woodland Ceremonial Site in Southeastern Massachusetts. *Bulletin of the Massachusetts Archaeological Society* 71(1): 26-44
- Malville, J. McKim  
2004 Ceremony and Astronomy at Chimney Rock. In *Chimney Rock, the Ultimate Outlier*, edited by J. M. Malville, pp. 131-150. Lexington Books, Lanham, MD.  
2008 *Guide to Prehistoric Astronomy in the Southwest*. Johnson Books, Boulder, CO.
- Martin, Frederick W.  
2001 "Solar and Lunar Sightlines at King Philip's Rocks," Fall meeting of the New England Antiquities Research Association, Stratton Mountain VT, Oct 20, 2001. (videotape recorded, presumably in NEARA archives; unpublished manuscript draft wp50\kpr\neara)  
2006 "GPS Survey at King Philip's Rocks in Sharon MA: Signal above Noise and Archaic Astronomical Date," Fall meeting of NEARA, MAS, and Eastern States Archaeological Association, Fitchburg MA, Nov. 11, 2006 (unpublished manuscript draft wp50\kpr\esaf3 )
- Martin, Fred W. and Elizabeth F. Martin  
2004 A Midsummer Sunbeam Site in New England. Pp. 287-296, in *Viewing the Sky through Past and Present Cultures*, T. W. Bostwick and B. Bates, eds.,. Phoenix AZ: Pueblo Grand Museum, Anthropological Papers No. 15. (selected papers from the 7<sup>th</sup> Oxford International Conference on Archaeoastronomy, June 2004).
- Mavor, James W., Jr., and Byron Dix  
1989 *Manitou*. Inner Traditions International, Ltd., Rochester, VT.
- Midgley, Polly  
2005 "Dolmens along the Croton" Unpublished oral presentation at Spring Meeting of the New England Antiquities Research Association, Danbury, CT, April 8, 2005.  
2006 "Dolmens in the Northeast" Unpublished oral presentation at Midwestern Epigraphic Society Research Symposium, Westerville, OH, April 22, 2006.  
2008 "Enigmatic Stone Chambers" Unpublished oral presentation at Spring Meeting of the New England Antiquities Research Association, Northhampton, MA, Apr 25, 2008.
- Milner, George R.  
2004 *The Moundbuilders, Ancient Peoples of Eastern North America*. Thames and Hudson, London.
- Romain, William F.  
2000 *Mysteries of the Hopewell*. Univ. of Akron Press, Akron, OH.  
2004 Journey to the Center of the World: Astronomy, Geometry, and Cosmology at the Fort Ancient Enclosure. Pp. 66-83, in *The Fort Ancient Earthworks*, edited by R. P. Connolly, Bradley T. Lepper, Ohio Historical Society, Columbus.

Waller, Joseph N.

- 2010 Recent Examination of a Native American Burial in Nemasket Indian Territory, Southeastern Massachusetts. *Bulletin of the Massachusetts Archaeological Society* 71(2):58-66.

Thom, A

- 1967 *Megalithic Sites in Britain*. Oxford U. Press.  
1971 *Megalithic Lunar Observatories*. Oxford U. Press.

Thom, A, and A. S. Thom

- 1978 *Megalithic Remains in Britain and Brittany*. Oxford U. Press.

Thomas, C.

- 1891 *Report on the Mound Explorations of the Bureau of Ethnology*. Smithsonian Institution, Bureau of Ethnology, 12th Annual Report. Washington, D.C.

Trento, Salvatore M.

- 1978 *The Search for Lost America, Mysteries of the Stone Ruins in the United States*. Penguin Books., New York.